



TEMPERATURE REGULATORS NARROW BAND

SECTION I - INSTALLATION

CLASSES*			
HEATING		COOLING	
GTK	GTB	GTS	GTRK(J)

*Also all of the above regulators that include A, C, and/or J in the class designation.

Do not use red lead or cement in making up joints.
Use pipe thread compound sparingly on male threads.

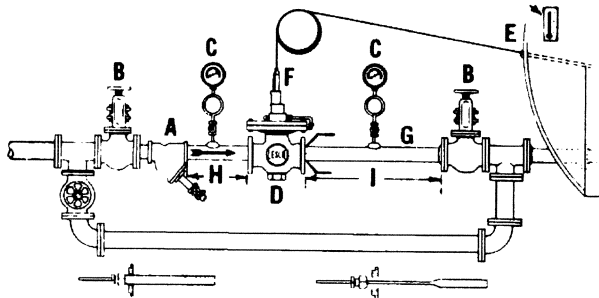

Figure 1

Provide parts removal space around regulator.

PIPING DETAILS

NOTE:: To provide lowest noise and velocity factors; dimension "H" and "I" (length) should be 3 feet to 5 feet. Expand outlet line to size of inlet steam connection of heater.

1. Protect regulator from scale and dirt with self-cleaning strainer.
2. Install stop valves and pressure gauges (C) to control setting and operation of regulator. For maintenance without shutting down heater or process, a bypass should be included.
3. Blow out pipe lines thoroughly before installing regulator.

4. Line gaskets should have same outside diameter as flanges and 1/4-inch larger inside diameter than bore of flange.
5. Install regulator (D) (without thermostatic element) upright in horizontal pipeline with arrow (cast on body) pointing in direction of flow.
6. Install bulb casing or stuffing box into side or bottom of vessel so that thermostatic bulb will feel true temperature of the fluid under control. Do not locate bulb closer than six inches to source of heat or coolant. Avoid placing bulb in direct path of injected steam or cooling medium.
7. Remove adjusting sleeve (F) from regulator, insert bellows and screw bellows swivel nut into sleeve full distance. Tighten securely. Replace sleeve on regulator and screw downward a few turns. Lock in place.
8. Place bulb and spring in casing or install bulb in stuffing box (E). Install and tighten bulb casing nut or stuffing box nut.
9. Handle flexible tubing carefully and arrange location for maximum protection.
10. Thermometer and thermostatic bulb should be at the same location for an accurate check of regulator action.
11. For injection heating, place regulator above maximum water level in tank. Install check valve on outlet side to prevent water backing up into regulator.
12. For cooling service, a small constant circulation of coolant may be desirable and should be provided by a small bypass with needle valve or orifice (in classes containing letter "J" a small constant flow of coolant is handled through an internal bypass.)

SECTION 11—OPERATION

HEATING SERVICE — CLASS GTK, GTB AND GTS

1. Slowly open inlet stop valve and dispose of condensation, dirt, etc., by opening strainer blow-off valve.
2. Slowly open outlet stop valve.
3. At start regulator is wide open and heating will be rapid. When desired temperature is nearly reached, loosen lock nut and turn down on adjusting sleeve (F) until regulator closes at the desired temperature. Tighten lock nut. For regulators fitted with calibrated dial see page 5, Section IV.
4. Check controlled temperature after a period of operation and readjust sleeve if necessary. To increase temperature setting, gradually turn adjusting sleeve out of bonnet until regulator maintains desired temperature. To decrease temperature, turn adjusting sleeve into bonnet.
5. To turn steam off, close inlet stop valve.
6. To turn steam on (with regulator set) keep outlet stop valve closed until inlet stop valve is opened

COOLING SERVICE—CLASS GTRK—GTRB

1. Slowly open inlet stop valve and dispose of dirt, etc., by opening strainer blow-off valve.
2. Screw Adjusting sleeve downward all the way, opening regulator fully. Open outlet stop valve supplying cooling water to equipment.
3. Observe temperature on thermometer, and when desired temperature is nearly reached, back off adjusting sleeve until regulator throttles and closes at the desired temperature. For regulators fitted with calibrated dial, see page 5.
4. Check controlled temperature after a period of operation and readjust sleeve if necessary. To increase temperature setting, gradually turn adjusting sleeve out of bonnet until regulator maintains desired temperature. To decrease temperature, turn adjusting sleeve into bonnet.
5. To turn coolant off, close inlet stop valve.

SECTION III—MAINTENANCE

Leslie Temperature Regulators may be dismantled without removal from pipe line when maintenance checks are desired.

Check nameplate for proper class and write for applicable drawings.

REPLACING STEM SEAL FOR VALVE STEM

Worn stem seal should be replaced as follows:

1. Remove adjusting sleeve (51), hold pilot stem (7) by placing pin in hole and remove stem screw, freeing springs and seats.
2. Remove bonnet (1) from housing (6). Clean stem. Do not use abrasives.
3. Replace pilot stem in bonnet. Remove worn O-ring, and replace as described in figure 2.
4. Reassemble bonnet gasket (34) and bonnet (1) to pilot housing and tighten in place.
5. Replace seats and springs in order with short spring on bottom and two long ones on top.
6. Hold pilot stem by placing pin in hole. Place top spring seat and stem screw in position on springs. Press seat down tightly against springs compressing them until screw can be easily run into stem. Tighten.
7. Reassemble adjusting sleeve (51) and element on bonnet (1) and readjust for temperature. Tighten.

REPLACING STEM SEAL - GT CLASS

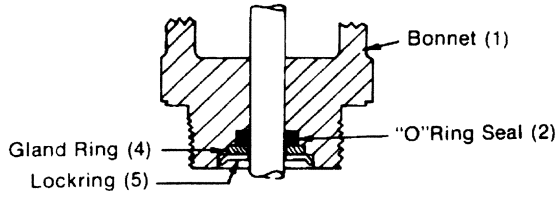

Figure 2 - Stem Seal Classes

To remove O-Ring seal (1), take out lockring (5) and gland ring (4), then O-Ring.

To install O-Ring seal, moisten O-Ring with lubricant and place in counterbore in bonnet. Insert gland ring in its recess in bonnet, then press lockring in place (firmly against gland ring) and with prongs positioned as shown in figure 2.

DISMANTLING

Close stop valves on inlet and outlet sides of regulator and open strainer blowdown valve to vent trapped fluid.

1. Remove adjusting sleeve and element.
2. Remove all copper tubing.
3. Unscrew bonnet (1) from pilot housing (6). Remove gasket.
4. Take out pilot housing cap screws and remove pilot housing (6) and pilot housing gasket (34).

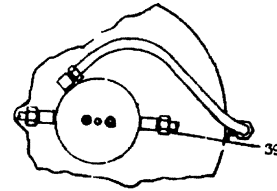

Figure 4. - By-Pass for Constant Bleed "J" Feature Only

IMPORTANT NOTE Place diaphragm leaf with 1/16" hole on bottom.

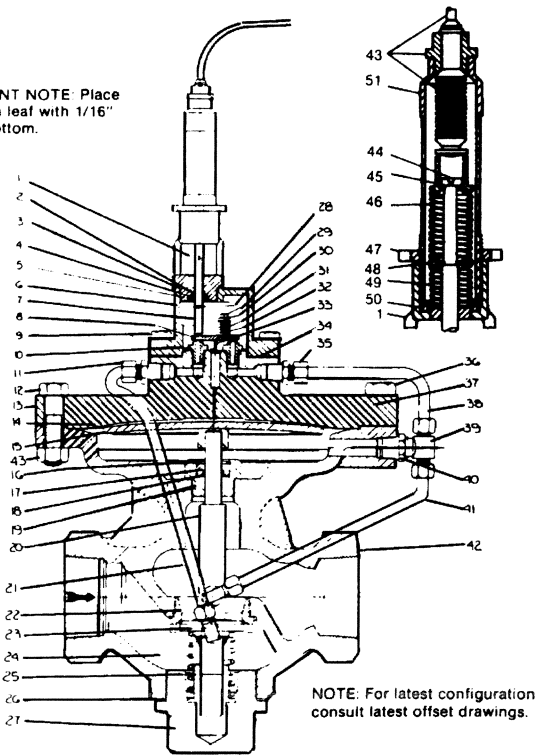

Figure 3 - class GTK Temperature Regulator

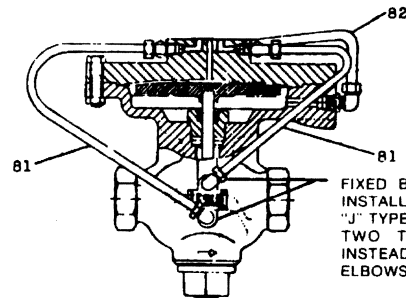

Figure 5. - Tubing Arrangement for Classes GTRK-5 & GTRJK-5 (Cooling Service)

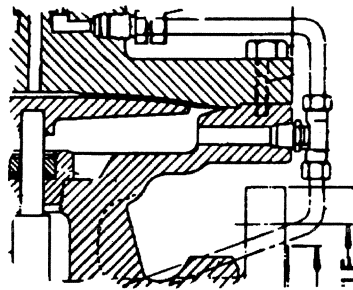

Figure 6. - Tubing Arrangement for 1/2" to 1-1/2" Class GTK-5 and 2" Class GTK-3 (Heating Service)

5. Remove pilot lever (8). Clean seating surfaces. Examine and clean pilot nozzles (10). If damaged replace only with nozzles required for the particular size of regulator. See applicable drawing for correct reference number. Reassemble parts.
6. Remove pilot flange with reassembled parts and pilot flange gasket from diaphragm cover (13).

NOTE: Step 6 applies only to units designed with pilot flange assembly. Newer units have one piece diaphragm cover and pilot flange design.

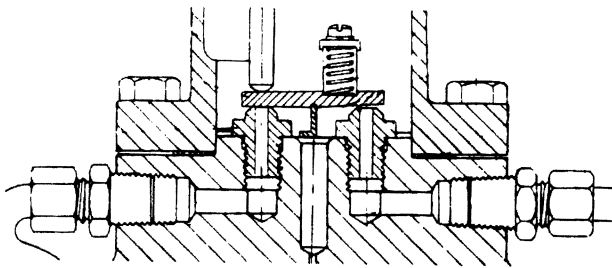

Figure 7 - View showing one piece diaphragm cover and pilot flange design.

7. Unbolt and take off diaphragm cover (13). Lift out diaphragm (two leaves) (14) and diaphragm disc (15). Lift out diaphragm disc with two hooks formed out of 1/16" diameter wire.
8. Loosen and remove bottom cap (27). Gasket (26), main valve spring (24) and valve plug (20) will follow
9. Seat ring (22) in body can be taken out if necessary with the special seat ring wrench provided for this purpose.

CLEANING

Clean all parts with an approved solvent and check as follows:

1. Examine main valve, seat ring and guides. Remove any encrusted material with crocus cloth. Do not use abrasive on Teflon-coated pilot stem.
2. If valve plug or seat ring seating surfaces are scored or cut, regrind with fine grinding compound. Remove all traces of grinding compound before reassembling.

NOTE: If main valve, seat ring or both are remachined due to damage to seating surfaces, it will be necessary (in order to maintain correct diaphragm disc to diaphragm seat dimension) to shorten main valve by removing from the top (diaphragm) end an amount of metal equal to the total removed from seat ring and/or main valve. Clearance between diaphragm and diaphragm cover is to be 1/16".

Step 2 Does Not Apply To Resilient Seat.

Caution: Leslie temperature regulators are ruggedly built and dimensioned very accurately. Do not change any dimensions.* To assure long life, complete later changeability and low maintenance cost, use only standard Leslie parts.

*Other than that covered in note above.

ASSEMBLY

1. Graphite or compound should not be used on joints. Moving parts require no lubricant except as noted for seat ring (figure 3).
2. Place valve plug (20), spring (24) and gasket (26) in position on bottom cap (27), and screw to body. Tighten.
3. Place diaphragm disc (15) on valve plug with guide over stem end.
4. Make sure that faces of diaphragm cover (13), body (42) and diaphragm (14) are perfectly clean in order to insure tight sealing joint. Position diaphragm (two leaves**) (14) on diaphragm disc (15) making sure that diaphragm is properly in body recess. Assemble diaphragm cover (13) to body. Assemble bolts and nuts to regulator. Snug up bolts evenly on alternate sides of the regulator, then tighten. Reconnect tubing. **See note Figure 3.

5. Install pilot flange gasket, pilot flange, and pilot housing with assembled parts. Be sure that dowel pin (27) is in proper dowel pin hole in top of pilot flange for the particular service required. (Dowel pin hole stamped "H" is for heating service; dowel pin hole stamped "C" is for cooling service.) For units with this type of design .
6. Replace adjusting sleeve (51) and thermostatic element. Adjust for temperature as shown under Section II, Operation.

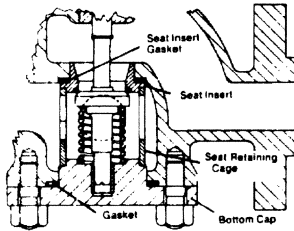

STEEL VALVES FITTED WITH CAGE TYPE TRIM
Figure 8 – Cage Type Trim.

When dismantling steel valves, the seat insert, seat-insert cage and the seat-insert gasket may be easily removed for inspection, cleaning or rework after the bottom cap and other parts have been taken out. When reassembling, always use new seat insert and bottom cap gaskets. Tighten bottom cap down evenly until the faces of the bottom cap and main body meet.

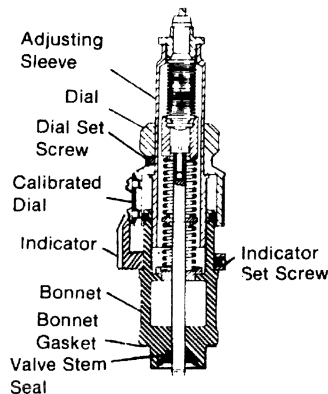

To add or adjust calibrated dial (see figure 4). Class GTK, GTRK, etc. type regulators.

Figure 9 – Calibrated Dial Assembly

SECTION IV
CALIBRATED DIAL ASSEMBLY

1. Remove plain bonnet assembly from regulator and replace with calibrated dial bonnet assembly using bonnet gasket.
2. Loosen indicator set screw and dial set screw with Allen head set screw wrench.
3. Move indicator to position convenient to read and tighten indicator set screw.
4. Turn adjusting sleeve counterclockwise several turns. Install bellows of thermostatic element in adjusting sleeve and tighten swivel nut. Install bulb into bulb casing or stuffing box where temperature is to be controlled. Heat or cool system to temperature within range of element. Measure temperature at bulb location with an accurate thermometer.
5. Adjust regulator as follows:

Heating Service: Turn adjusting sleeve clockwise until regulator cuts off flow of heating medium. Then turn adjusting sleeve back just far enough to start a slight flow.

Cooling Service: Turn adjusting sleeve clockwise until regulator just starts to pass cooling medium.

6. Calibrate regulator by turning calibrated dial so that scale reading at indicator corresponds to thermometer temperature. Tighten calibrated dial set screw.
7. Dial adjustment is now set for use at any temperature on the scale. Turn dial to desired temperature.