

REVISIONS			FILE NUMBER
ECN NO.	REV	DESCRIPTION	90G-X079J
			DATE DR. BY APPD
	1	PT. NO'S. 12 & 14 WERE CL2A, PT. NO. 13 WAS GR1117	10/23/90
	2	ADDED POSITIONER TO ACTUATOR VIEW	4/16/93 S.E.N
1091	3	QTY P/N'S 13,14 WAS 4	9/5/95 RDV
2358	4	ADDED P/N 17 - NAMEPLATE & BRACKET	6/25/03 RDV

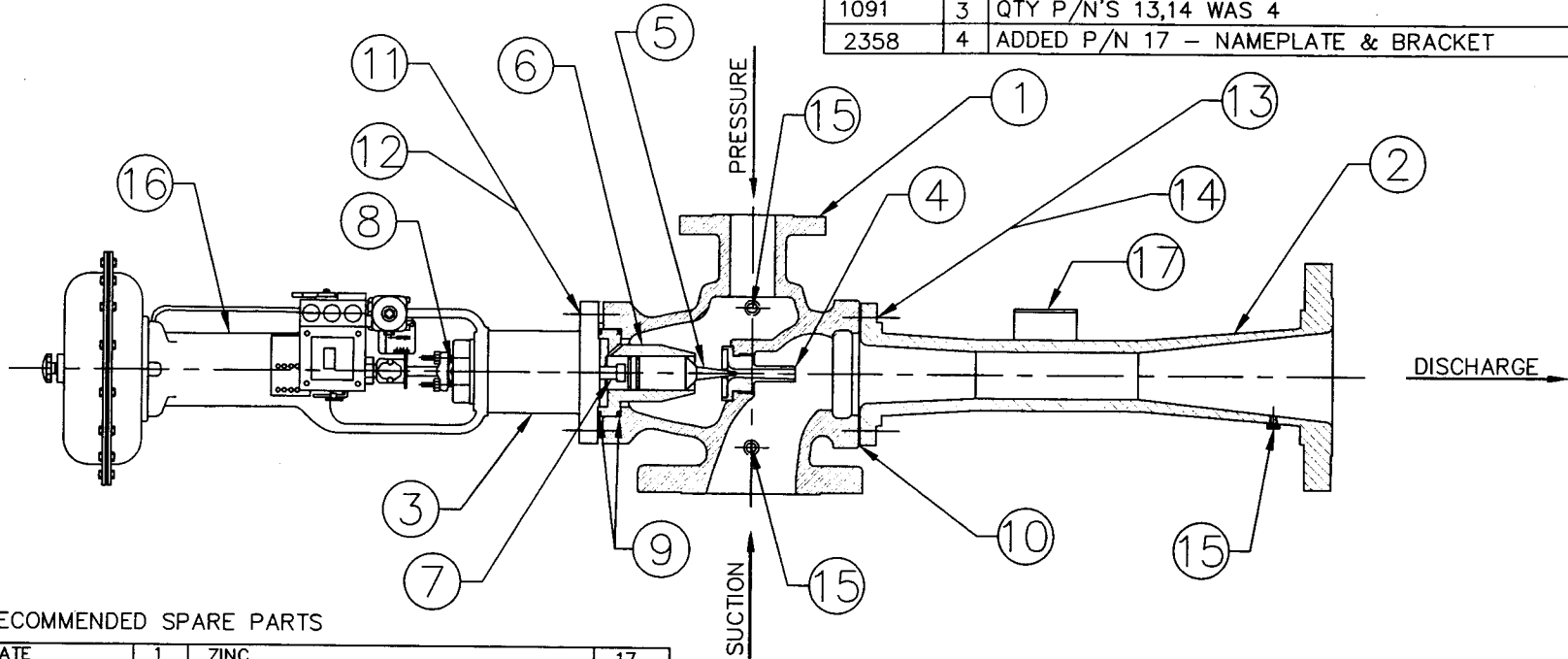

* RECOMMENDED SPARE PARTS

NAMEPLATE	1	ZINC	17
FISHER ACTUATOR	1	TYPE-667	16
PIPE PLUGS	3		15
HVY HEX NUTS	8	STL A194 GR4	14
STUDS	8	STL A193 GRB16	13
HVY HEX NUTS	8	STL A194 GR4	12
STUDS	8	ALLOY STL. A193 GRB16	11
GASKET	1	GRAFOIL	10*
GASKET	2	FLEXITALLIC-SST/GRAFOIL	9*
S.B. PACKING KIT	1		8*
SPINDLE ROD	1	SST A276 TP.304	7
SPINDLE GUIDE	1	STL A108 GR1117	6
SPINDLE	1	SST A-582 TYPE 416	5*
NOZZLE	1	SST A276 TP.304	4*
STUFFING BOX	1	STL A108 GR1018	3
TAIL	1		2
BODY	1		1
DESCRIPTION	NO. REQ'D	MATERIAL	PT. NO.

THIS DRAWING IS THE PROPERTY OF SCHUTTE & KOERTING <small>BENSLEM, PENNSYLVANIA 19020</small> AND IS LENT WITHOUT CONSIDERATION OTHER THAN THE BORROWER'S AGREEMENT THAT IT SHALL NOT BE REPRODUCED, COPIED, LENT, OR DISPOSED OF DIRECTLY OR INDIRECTLY NOR USED FOR ANY PURPOSE OTHER THAN THAT FOR WHICH IT IS SPECIFICALLY FURNISHED.		CERTIFIED FOR _____ DATE _____ ORDER NO. _____ BY _____ S&K ORDER NO. _____	
UNLESS OTHERWISE NOTED: DIMENSIONS ARE IN INCHES BOLT HOLES STRADDLE ϕ 'S		DO NOT USE FOR CONSTRUCTION UNLESS CERTIFIED FOR A SPECIFIC ORDER	
FIG NO. 426 S. O. B. M. MADE FROM FILMED		SCHUTTE AND KOERTING BENSLEM, PA. 19020 ASSEMBLY DRAWING FOR 3" & 4" AUTOMATIC THERMOCOMPRESSOR W/ FISHER ACTUATOR	
DR. TMS DATE 1-1-90 CHKD. MCV DATE 6/25/02 APP'D. SEN DATE 6/25/02		REDRAWN ON CAD RDV 5/18/90	
APP'D _____ DATE _____		SIZE C SCALE N.T.S.	CODE IDENT NO. _____ DRAWING NO. 90G-X079J 4 REV. _____ SHEET 1 OF 1